

Locomotive Sand Trailer

Our Locomotive Sand Trailer meets the following Buy America Requirements.



Components

- Trailer
- Compressor
- Sand Tank
- Sand Hose & Nozzle



Brief Functional Description

Railquip's mobile sand system trailers make filling locomotives with traction sand safer, easier, and faster. These trailers are designed to be safely towed by existing trucks and easily stored when not in use, offering a convenient solution for cases in which the locomotive is away from the service station or as an addition to an existing sanding system.

The operation process is simple. The sand trailer is positioned near the locomotive, the sanding system is charged using an on-board diesel-powered air compressor and the sanding wand is placed in the locomotive's sandbox filling port. The operator opens the discharge valve to transfer the sand from the hopper into the sandbox. Once the sandbox is filled, the operator closes the discharge valve, uses the purge valve to eliminate sand spills and disconnects the hose.

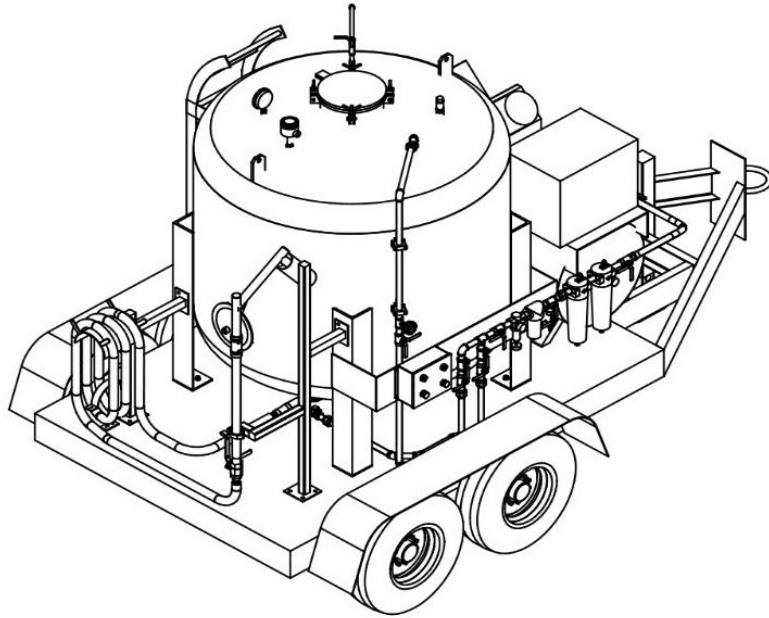

Technical Data

Trailer

- 16' long, GVW of 15K lbs.
- DOT approved with Title
- 2-axes with spare tire
- Pintle hitch and 7-pin plug

Compressor

- Horsepower: 10 hp
- Type: Diesel Fuel
- Can be removed if using locomotive or shop air

Sand Tank

- Sand Capacity: 10,000 lbs. Silica Sand (Locomotive Traction Sand)
- Wet Receiver: 30 gallon

Sand Hose & Nozzle

- Nozzle: Candy Cane Style for Locomotives, 74" Flex Head, SS Ball Valve Hose
- Length: 30 Feet
- Hose Size: 1.5"

Sand Delivery Rate

- Sand Flow: ~1 cu. ft. / min.
-



Safety Features & Benefits

Core Features

- Increased mobility vs. sand skid systems
- Locomotive sand wand nozzles
- Weather protection systems
- Pressure purge systems
- Various fill methods
- Integrated air compressors
- Outsourced air reels
- Elevated platforms and safety steps
- Multi-wand capable

Additional Features

- Sand Tank Hi & Lo Level Indication
- Auto-shutoff sand wand when filling locomotive sand box
- Start / Stop Station
- Control Panel w/ Pneumatic Distribution Valves
- 4-gal air receiver



Ask about different sizes
and available options.

IF RAILQUIP

Contact us for more info:

Ron Covert

PRODUCT SPECIALIST

 ron@railquip.com

 (864) 354-3984



 (770) 458 4157

 railquip.com

 sales@railquip.com

IF RAILQUIP

KEEPING AMERICA MOVING

3731 Northcrest Road, Suite 6 - Atlanta GA, 30340